

## **Sand Control**

Marine deposited sands, most oil and gas reservoir sands, are often cemented with calcareous or siliceous minerals and may be strongly consolidated. In contrast, Miocene or younger sands are often unconsolidated or only partially consolidated with soft clay or silt and are structurally weak. These weak formations may not restrain grain movement, and produce sand along with the fluids especially at high rates.

Fluid movement causes stresses on the sand grains because of the fluid pressure differences, fluid friction and overburden pressures. If these stresses exceed the formation-restraining forces, then the sand will move and be produced. Rapid changes in flow rates and fluid properties cause unstable conditions which can result in increased sand production. It has been shown that particle movement occurs in multiphase flow when the wetting fluid starts to move (Mueckle).

### **Consequences of Sand Production**

Production interruptions can be caused by sand plugging the casing, tubing, flowlines and separators.

Casing collapse can be caused by changes in overburden pressures and stresses in the formation.

Downhole and surface equipment can be destroyed, downtime and replacement costs, spills and in extreme cases a blowout.

Disposal of produced sands is costly.

### **Methods of Sand Control**

Restricting the production rate of the well. This reduces the drag forces on the sand grains. This is often an uneconomical solution. Increasing the number and diameter of the perforations also reduces the flow velocity and drawdown pressures.

Gravel packing is the oldest and simplest method of sand control. Works in both on and off shore wells.

Sand consolidation; resins are injected into the formation binding the grains of sand while leaving pore spaces open.

Resin coated gravel packs; gravel coated with resin is placed in the casing and perforations. The resin binds the grains together which results in a strong but permeable filter. The excess is drilled out of the casing so the well is produced with a full opening wellbore. This can be used with or without a screen, can be placed using coiled tubing.

The method of sand control will depend on such parameters as grain-size distribution, clay content, interval length, well deviation, flow rate and of course costs.

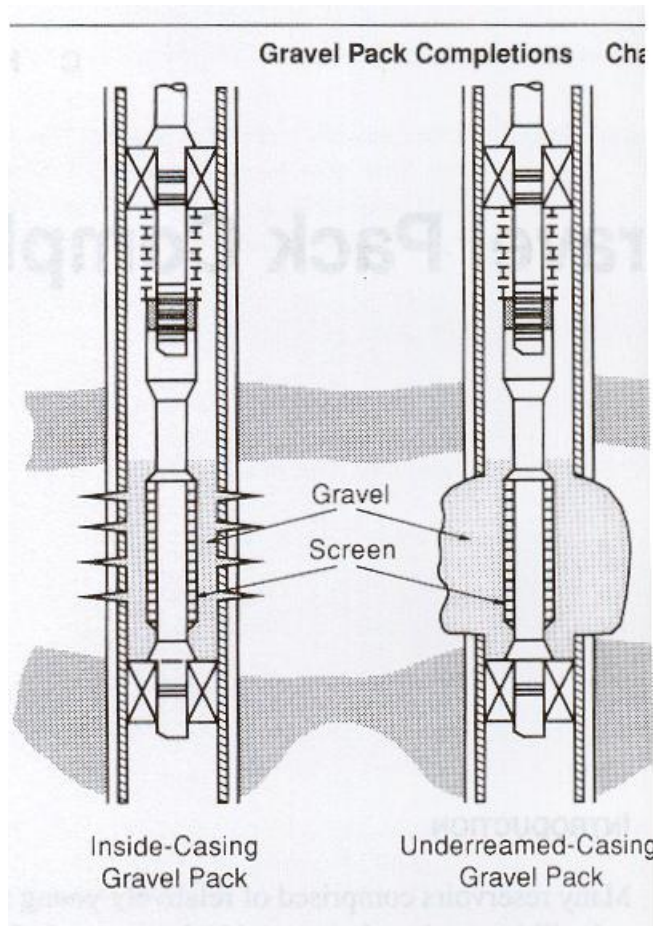

Procedures in designing gravel packs

Type of completion; cased or open hole.

Formation sampling, it is very important to know the sand grain size distribution in the formation. The best samples are obtained using a rubber sleeved core barrel. Sidewall cores are the next best technique for getting

samples. Bailed or separator samples should not be used, being small grained biased.

Best case a full formation analysis should be run, this would include acid solubility, clay content, fines.

Gravel Selection; the gravel should be sized to prevent the invasion of the pack by the finest of the formation sand but not reduce the flow of fluids. Quality control of the gravel is important. The amount of particles that are smaller than the specified range can affect the permeability of the pack.

To size the gravel a sieve test is run on the formation sample, the results are plotted on semi log paper, grain diameter vs. cumulative percent by weight. This should form a s shaped curve. The mean diameter size of the gravel is:

$$D_g = \text{or } 6 \overline{D}_{f50}$$

$D_g$  is the mean diameter of the gravel,  $D_{f50}$  is the diameter of the formation grains at the 50% weight.

Screen selection; there are many types of wire wrapped screens available. The wrapping wire is usually made of 304 stainless steel, while the pipe core is Pipe Grade S or K. For gravel packing the gauge of the screen should be small enough to prevent the passage of the gravel sand.

#### Installing Gravel Packs

Well preparation; The tubing should be as clean as possible to prevent contamination of the pack. The completion fluids also should be as clean as possible, no solids floating around, silt or organic.

If a cased hole completion the cement bond should be checked, very important to have a good bond to control the placement on the pack. The perforation tunnels must be opened for good placement of the pack. The number and size of perforation is also important. The more the better, and the larger the better, this helps keep the fluid flow laminar, lower pressure drop.

Any clay problems should be resolved before the placement of the gravel pack.

The gravel is pumped down the well in a viscous fluid similar to frac fluids. A breaker is included just like frac gels, to break down the fluid after the placement to facilitate clean up.

## Placement of Gravel Pack

One method of placement is the reverse circulation method. The gel and gravel is pumped down the annulus of the well after the screen has been placed on bottom. The carrier fluid then passes into the formation and through the screen and is returned to the surface up the tubing. The major disadvantage with this method is the possibility of pumping debris down with the pack.

The crossover method is a much cleaner method with less chance of contamination the pack while placing the gravel. The gel and gravel is pumped down the tubing, crossover to the screen annulus below a packer. The carrier fluid then passes through the screen and is returned to the surface in the tubing casing annulus.

Both these methods are used in open and cased holes. Another method in cased holes is the wash down method. In this method the gravel is placed across the interval before the screen. Then the screen is washed down to its final position.

