

Data Acquisition

1 Objectives

The objective of this laboratory exercise is to introduce fundamental concepts in data acquisition and familiarize students with data acquisition procedures supported by the MRK controller board. The key topics include introduction to analog to digital conversion, resolution and sampling. Theoretical discussion is illustrated with a practical example of distance measurements using the infrared sensor.

2 Theoretical Background

A typical data acquisition system consists of a sensing element, data conditioning unit and a spectrum of components responsible for data processing/storage, information retrieval and display. In the analog system, such as a traditional oscilloscope, all this is done using analog amplifiers, limiters, heterodyning circuits, filters, CRT display and other analog devices. In contrast, the data acquisition process in the digital system is centered on the analog to digital (ATD) conversion of the measured signal. The purpose of a signal conditioning unit in the digital DAQ system is to reduce noise and amplify / reduce amplitude of the measurement signal to fit within the voltage range acceptable by the ATD converter. A number of methods exist to convert the analog signal into its digital equivalent: flash or parallel conversion, conversion by successive approximation, and conversion using a dual slope algorithm. The MC9S12 integrated into the MRK controller board includes two 8 or 10 bit multiplexed input successive approximation ATD converters. In the successive approximation method, first a trial value between converter's maximum and minimum input voltages is generated; then, it is compared with the signal value to determine which half of the range will be further used in successive approximations. The selected upper or lower portions of the range is further divided into two sub-ranges and the process continues until an N-bit approximation of a signal amplitude is reached. Resolution of an ATD converter is determined using the following formulation:

$$\delta V = \frac{V_{Range}}{2^N}, \quad (1)$$

where $V_{Range} = V_{Max} - V_{Min}$ are the maximum and minimum voltages acceptable by the converter and N corresponds to bit resolution (8 and 10 in the case of MC9S12).

Applying Equation (1) to input parameters of the MC9S12 ATD converter yields:

$$\delta V_8 = 5/256 \approx 0.02 \text{ V}; \delta V_{10} = 5/1024 \approx 0.005 \text{ V}.$$

The result of an ADT conversion is a digital value that represents the amplitude of the converted signal. Conversion of the digital result into equivalent analog amplitude is straightforward:

$$V = \frac{V_{Range} \cdot V_{Digital}}{2^N - 1}, \tag{2}$$

The speed of the ATD conversion is defined by the sampling rate. At the maximum bus clock frequency of 24 MHz, ATD converter of MC9S12 produces one conversion every 7 μs. Knowing the sampling rate is important for processing measurement signals which rapidly change in time. For correct representation of such signals, the converter must sample at least twice as fast as the signal change. This rule is mathematically presented as

$$\delta t < \frac{1}{2f_{max}}, \tag{3}$$

where f_m is maximum frequency of the input signal. Formulation (3) implies that MC9S12 ADT converter should be used for digitizing signals with periods larger than 14 μs.

In this laboratory exercise, an GP2D12 infrared sensor is utilized for distance measurements. The infrared sensor consists of a LED emitting the infrared light and a position sensing devise (PSD) that outputs voltage based on results of the triangulation procedure. Measurement of the distance using triangulation is illustrated in Figure 1. The angles in a triangle connecting the IR emitter, a distant object and PSD are dependent on a position of the object with respect to LED/PSD plane and therefore, are used to calculate the distance between IR sensor and the object. Maximum range that can be detected using the GP2D12 is from 10 to 80 cm. It is also sensitive to alignment of the surface being measured (please see sensor specification for details). Typical Output/Distance Characteristics of GP2D12 are presented in Figure 2.

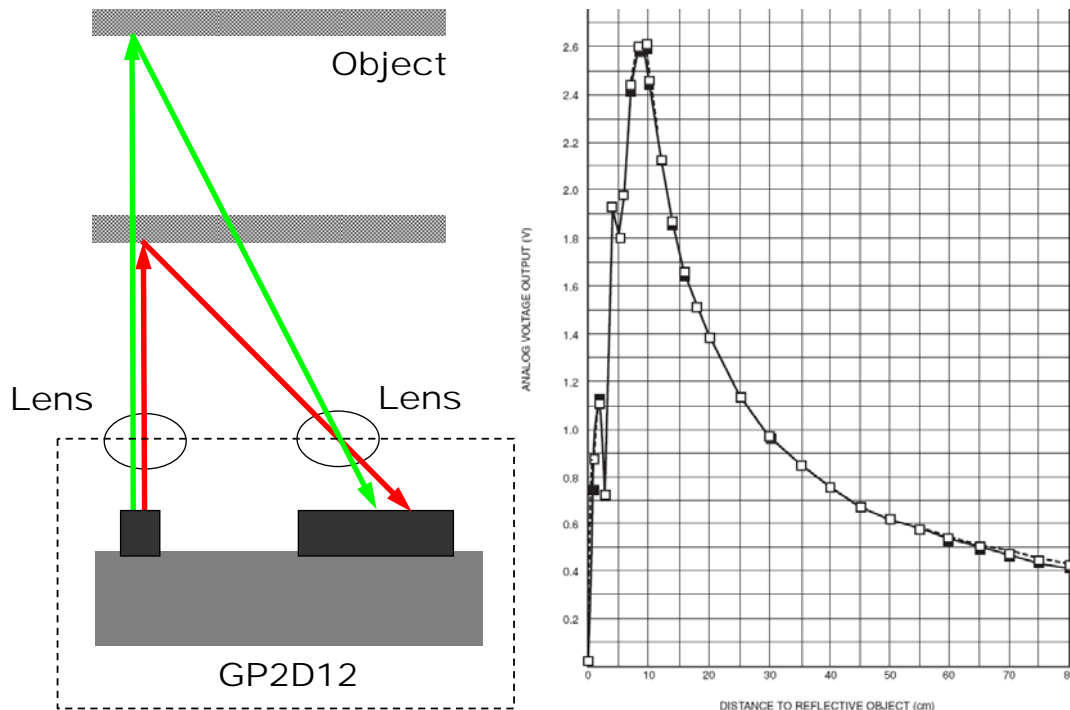
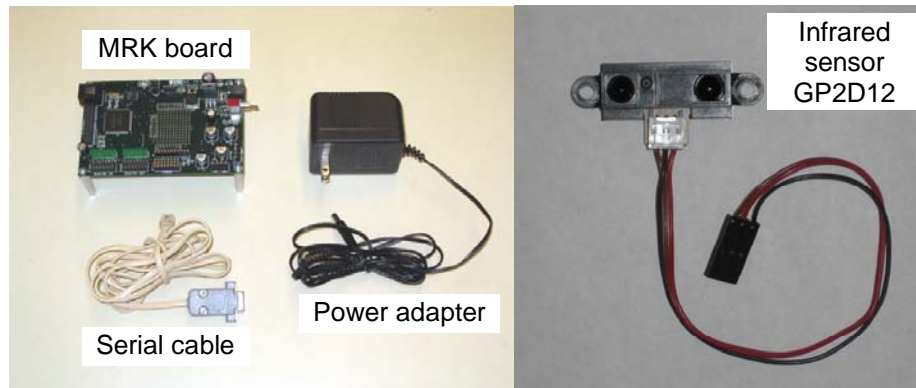

Figure 1 Triangulation measurements using the GP2D12 IR sensor and its output/distance characteristics.

3 Equipment



- MRK board
- Serial communication cable
- Infrared sensor GP2D12
- Power adapter
- Function generator
- Measurement tape

4 Procedures

In this laboratory exercise we will explore two data acquisition modes supported by the MRK board: *instantaneous* DAQ and *continuous* DAQ. These modes are used to study effect of the sampling rate. Measurement resolution is investigated by comparing the data records digitized by the 8 and 10 bits ATD converters.

The experimental setup includes the MRK controller board, an infrared sensor to measure a distance between the sensor and a screen (your hand or a mouse pad), and a measuring tape to correlate results of the sensor output and the actual distance.

Below is a general outline of the experiments.

Exercises 1 – 3: Use MRK and respective data acquisition modes to measure the distance when the screen is located 9, 18, and 27 inches away from the sensor. You will obtain 3 data records for the *instantaneous* mode and 3 data records for the *continuous* mode. In these measurements, resolution of your A/D converter is 8 bit. Change resolution to 10 bit and repeat measurements (i.e. another 6 records).

Exercise 4: Using the *continuous* DAQ mode with 8 bit resolution, measure the distance at least at 10 points within the 0 to 27 inches range.

Exercise 5: Repeat measurements in Exercise 4 using the DAQ program that allows for acquiring the data in a selected range (example: from 9 to 18 inches).

4.1 Configuring MRK controller board for the *instantaneous* DAQ mode.

In the *instantaneous* mode (high sampling rate – HSR), the analog signal is sampled with the maximum sampling rate and a record is stored in RAM; then, a serial communication interface is used to transfer data from RAM to PC via the MRK terminal program. Although, this mode

allows for very fast recording of the data, the data record is quite short (1024 points). This is because RAM memory resources (12kB) are limited and it can not accommodate a longer record.

To configure *instantaneous* mode, follow a general procedure for interfacing the MRK controller board with the PC using a serial cable. In this laboratory exercise, we use infrared (IR) distance sensor GP2D12 manufactured by SHARP corporation. The connection diagram for the IR sensor is depicted in Figure 2.

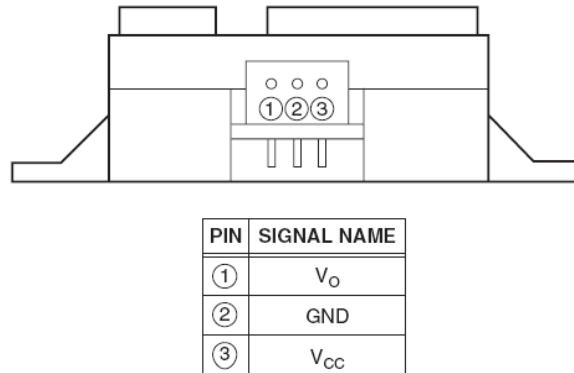

Figure 2 Connection diagram for SHARP GP2D12 IR sensor (SHARP application note)

In most of the sensors, the pins indicated above would be connected to black wire (GROUND), brown wire (SIGNAL), and red wire (POWER). Connect the sensor's cable to **pin 2** of the ANALOG_IN of the MRK controller board. Make sure that pins of the analog input port correspond to respective wires of the sensor connector. Show your set up to TA **before** powering the MRK board. Start the MKR terminal and Eclipse programs, create a new project in Eclipse. The following program enables the *instantaneous* DAQ mode.

```
#include "MRK.h"

int main() {
    int i;
    int numbers[1024];
    analog_in(RESOLUTION, 8);
    i=0;
    fprintf(SCI0,"Press a key to get data.\n\r");
    fgetchar(SCI0);
    while (1) {
        numbers[i] = analog_in(IN, 2);
        i++;
        if (i == 1024) {
            for (i=0;i<1024;i++) {
                fprintf(SCI0, "%d\n\r", numbers[i]);
            }
            break;
        }
    }
}
```

Input, assemble, and download a program to the MC9S12 microcontroller. Run the program from memory location 1000. The note "Press a key to get data." appears on a screen. Click on Main Toolbar > Transfers > Receive Text File.... Then specify the name of a file where you

would like the sensor data to be stored. The syntax should be *Name.txt*. Click Ok. An additional toolbar appear at the bottom of the command window. Press any key to get data. The data is displayed on a screen. When last number is displayed, click Stop on a lower toolbar. Your data is stored in *Name.txt*. To verify the data you may use either WordPad or Matlab[®]. To make file readable by Matlab's `textread` function, open *Name.txt*. and delete `MRK>` at the end of a file. Plot your data; use markers to indicate datapoints (i.e. sampling). Your results should look similar to the illustration below.

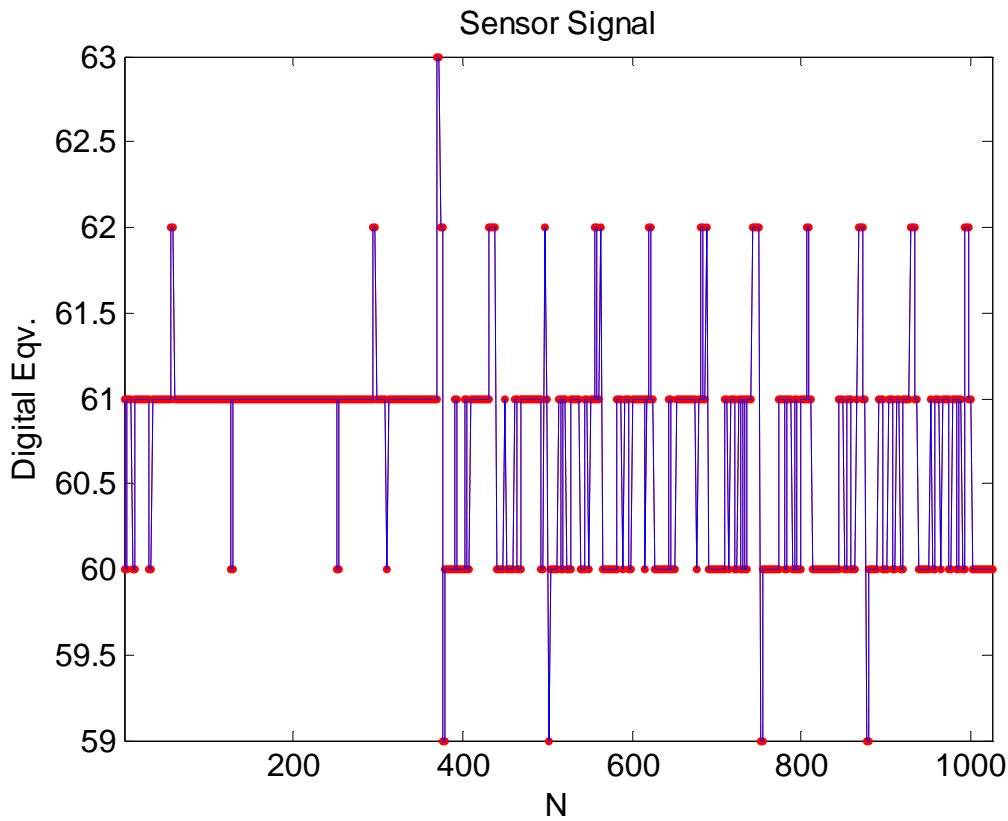

Figure 3 Output of the IR sensor versus sample number, 8 – bit conversion.

Exercise 1:

Using Equation (2) calculate the actual analog output of the sensor. Considering that the maximum sampling rate corresponds one datapoint every $7 \cdot 10^{-6}$ seconds, plot the sensor's output voltage versus the actual time. Calculate a mean value and standard deviation of the output voltage.

Exercise 2:

Modify the C program above to facilitate the 10 bit analog to digital conversion. Conduct the same measurement, generate the *.txt file, plot your results for both digital signal representation and the sensor analog output voltage. Calculate mean and standard deviation. Compare your 10 bit results with the data obtain using a 8 bit conversion. Discuss the difference. Which of the two produces more accurate results and why?

4.2 Configuring MRK controller board for the *continuous* DAQ mode.

Continuous DAQ (low sampling rate – LSR) takes advantage of a direct data transfer through the serial communication interface (SCI), and respectively, is limited by the speed of SCI. It takes approximately 1 ms for SCI to transmit a character and this essentially defines the data sampling rate.

Continuous DAQ mode is enabled using the following C code:

```
#include "MRK.h"

int main() {

    int i;
    int number;
    analog_in(RESOLUTION, 8);
    i=0;
    fprintf(SCI0,"Press a key to get data.\n\r");
    fgetchar(SCI0);
    while (i<1024) {
        number = analog_in(IN, 2);
        fprintf(SCI0, "%4d\n\r", number);
        i++;
    }
}
```

Exercise 3:

Compile, download and run the program. Plot the sensor output voltage as a function of time. What is the time difference between the datapoints and the sampling rate? Compare the low sampling rate (LSR) results with the high sampling rate (HSR) results. Are they different?

Exercise 4:

Modify the LSR example above to enable continuous DAQ with unlimited record length. Compile, download and run your program. Select a filename to store the measurement results. As soon as the data acquisition process is initiated, place the screen next to the IR sensor and slowly move it away until the maximum range (27 inches) is reached. Plot the output voltage of the IR sensor versus distance. Compare your results with (a) HSR and LSR data obtained in previous exercises (add averaged voltage amplitudes to your plot) (b) the Output/Distance characteristics available in the GP2D12 specification. Discuss similarities and differences. Ask colleagues from other two groups to provide data sets for Exercise 4. Is there any correlation between the data? What is the maximum and minimum deviation?

Exercise 5:

Using the program developed in the previous exercise, configure your system to acquire data in the range of 9 to 18 inches only. Signal amplitudes correspondent to other distanced should not be recorded. Provide visual indication of the data collection process by turning on LEDs of the Digital_out port. Plot your data.

5 Report and analysis requirements

5.1 Theory

Explain in your own words how the analog signal is converted to digital. Discuss key parameters of ADT conversion.

5.2 Results and analysis

Answer all questions in previous sections of these laboratory instructions.

Present and discuss your results.

Why knowing the maximum frequency of the measurement signal is important? How does this correspond to your results? Is there a considerable difference between HSR and LSR results? Discuss advantages and disadvantages of using LSR and HSR approaches to MRK-based DAQ.

How close is your output vs. distance dependence to the one presented in the sensor specification? Explain the difference.

*Last updated
October 4, 2006.*